

QUICK START GUIDE



Installing Cisco uBR-MC16U/X and uBR-E-16U Cable Interface Line Cards

- 1 Purpose
- 2 Feature Description
- 3 Prerequisites
- 4 Installing the Card
- 5 Removing the Card
- 6 Troubleshooting
- 7 Technical Specifications
- 8 Related Documentation

Warning

Only trained and qualified personnel should be allowed to install, replace, or service this product.

Caution

You must be properly grounded before handling this ESD-sensitive product.

1 Purpose

This quick start guide shows you how to install a Cisco uBR-MC16 cable interface line card in the Cisco uBR7200 series router.

2 Feature Description

The Cisco uBR-MC16 cable interface line card improves RF performance, supports spectrum management, increases system performance and supports online insertion and removal (OIR). The line card is available in three configurations:

- Cisco uBR-MC16U—With an onboard upconverter and green end tabs
- Cisco uBR-E-16U—With an onboard upconverter and slate blue end tabs
- Cisco uBR-MC16X—Without an onboard upconverter and yellow end tabs

3 Prerequisites

- The Cisco NPE-400 or the Cisco NPE-G1 or the Cisco NPE-G2 network processing engine must be used with this card.
- If you are using the Cisco uBR-MC16 line card to replace a different type of card, you must reconfigure the MC16U/X/E card.
- We recommend that you reload a Cisco 7200 series router when replacing a cable interface line card with a card of a different type.

4 Installing the Card

Note

The uBR-E-16U line card is an entry-level version of the uBR-MC16U line card, and fits only in the uBR7225VXR chassis.

- Step 1** Make sure that you are grounded.
- Step 2** Use both hands to grasp the line card by its metal carrier edges and align the line card with the slot guides, component side up.

Step 3 With the metal carrier aligned in the slot guides (see Figure 1), briskly slide the card into the card slot until you feel it seat in the backplane connectors.

Step 4 Tighten the captive screws.



Note The captive screws provide grounding for the electromagnetic interference (EMI) shielding.

Figure 1 Installing the Card in the Chassis

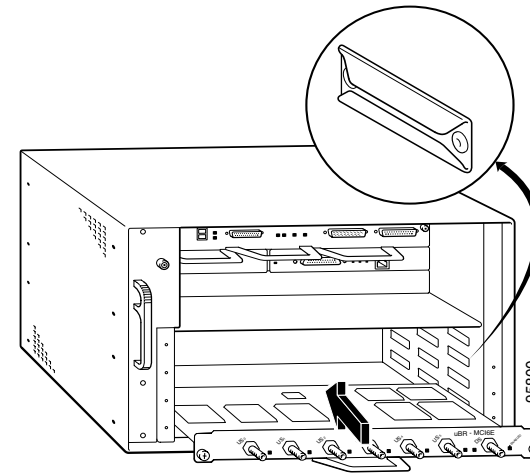

Note The cable interface line card insertion and removal method is the same for all the Cisco uBR7200 series routers.

Cabling

- Cisco uBR-MC16U—Green tabs
- Cisco uBR-E-16U—Slate blue tabs
- Cisco uBR-MC16X—Yellow tabs

Figure 2 Cisco uBR-MC16U

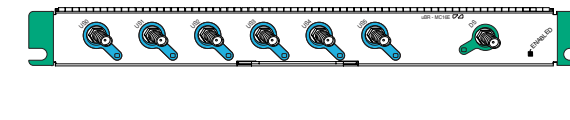

Cabling the Cisco uBR-MC16U/E-16U

The Cisco uBR-MC16U/E-16U cable interface line card has an onboard upconverter. To cable the card:

- Step 1** Connect the downstream cable to the downstream (DS) port.
The RF downstream port rings and end tabs are green for uBR-MC16U (see Figure 2) and slate blue for uBR-E-16U.
- Step 2** Connect the upstream cables to the upstream ports (US0—US5).

Cabling the Cisco uBR-MC16X

The Cisco uBR-MC16X cable interface line card (not supported on Cisco uBR7225VXR) does not have an onboard upconverter. The card may require up to 10-dB of attenuation due to a higher IF output power (higher than legacy Cisco cable interface line cards). To cable the card:

- Step 1** Connect the downstream cable to the downstream (DS) port on the card.
The IF downstream port ring and end tabs are yellow. See Figure 3.
- Step 2** Add RF attenuators as required to get the correct IF output. Insert the attenuator between the downstream IF output cable and the upconverter. See Figure 3.
- Step 3** Connect the upstream cables to the upstream ports on the card (US0—US5).

Americas Headquarters
Cisco Systems, Inc.
170 West Tasman Drive
San Jose, CA 95134-1706
USA
<http://www.cisco.com>
Tel: 408 526-4000
800 553-NETS (6387)
Fax: 408 527-0883

Cisco, Cisco Systems, the Cisco logo, and the Cisco Systems logo are registered trademarks or trademarks of Cisco Systems, Inc. and/or its affiliates in the United States and certain other countries. All other trademarks mentioned in this document or Website are the property of their respective owners. The use of the word partner does not imply a partnership relationship between Cisco and any other company. (0705R)

© 2009 Cisco Systems, Inc. All rights reserved.

Figure 3 Inserting an Attenuator

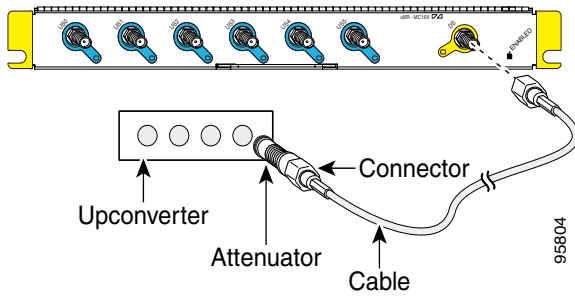

Note All upstream ports are light blue.

5 Removing the Card

To prevent the alarms from activating, administratively shut down the card using the **shutdown** command in interface configuration mode before removing it from the chassis.

- Step 1** Make sure that you are properly grounded.
- Step 2** Disconnect all the cables from the cable interface line card.
- Step 3** Unscrew the captive installation screws on the faceplate.

Figure 4 Removing the Card from the Chassis

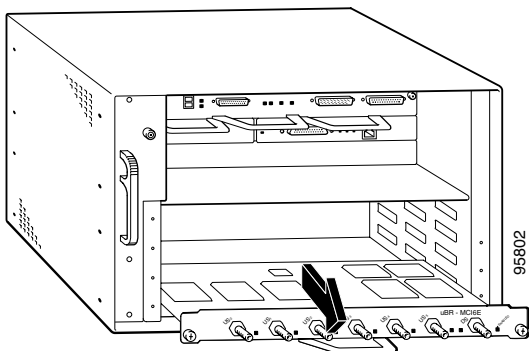

Step 4 Grasp the handle and carefully pull the card out of its slot (see Figure 4).



Caution Always handle the cable interface line card by the carrier edges and handle; never touch the card's components or connector pins.

Step 5 Place the card on an antistatic surface with the component side facing up.



Note If the card is being returned to the factory, immediately place it in a static shielding bag and proper packaging for protection.



Caution For proper cooling and airflow, always install a line card cover in an empty line card slot.

6 Troubleshooting

Check the following:

- 1.** Make sure that the card is securely seated in the chassis.
If the captive screws do not tighten all the way, the card is not properly seated in the chassis or backplane. Carefully pull the card halfway out of the slot, reinsert it, and tighten the captive installation screws.



Caution A partially seated line card can cause the router to reboot.

- 2.** Are *all* enabled LEDs on?
If yes, the system is operational.
If no, check the following possibilities:
 - a.** Verify that the card has been enabled and configured for operation. The enabled LED remains off when a card has not been configured and enabled.

- b.** If a port is enabled but its corresponding enabled LED is still off, check to see if the card has pulled away from the backplane. Reseat the card in its slot. (You do not have to turn off the system power to do this.) After the system reinitializes the interfaces, the enabled LED on the card should come on.

- 3.** If the enabled LED remains off after the above checks, it is likely that the system has detected a processor hardware failure.

Contact Cisco TAC for further information and help. To access the Cisco TAC website, use the URL: <http://www.cisco.com/tac>

Figure 5 LEDs

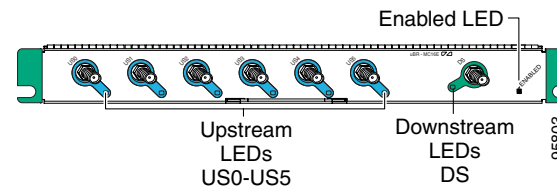

Table 1 LEDs/Status

LED/Status	Description
ENABLED—Green	Card operating normally
ENABLED—Off	Card not enabled
US—Green	Upstream enabled
US—Off	Upstream not enabled
DS—Green	Downstream enabled
DS—Off	Downstream not enabled

7 Technical Specifications

Table 2 Technical Specifications

Description	Order Num/ Specifications
Cisco uBR-MC16U, with upconverter	UBR-MC16U, UBR-MC16U=
Cisco uBR-E-16U, with upconverter	UBR-E16U, UBR-E16U=
Cisco uBR-MC16X, without upconverter	UBR-MC16X, UBR-MC16X=

Table 2 Technical Specifications (continued)

Description	Order Num/ Specifications
Blank covers	UBR-MC-COVER=
Weight—MC16U/E-16U	5.25 lbs (2.38 kg)
Weight—MC16X	4.75 lbs (2.16 kg)
Power	
MC16U/E-16U	62 Watts (211.6 BTU/h)
MC16X	47 Watts (160.4 BTU/h)
RF output power range—50 to 61 dBmV	
Output—MC16U/E-16U	+50 to 61 dBmV at RF
Output—MC16X	+42 dBmV at IF (+/-2 dB)
Modulation	
Upstream (US0–US5)	QPSK 8-, 16-, 32-, 64-QAM
Downstream (DS)	64-QAM, 256-QAM
Frequency range	
Upstream	5–65 MHz
Downstream	70–860 MHz

The Cisco MC16 line card is compatible with most cable systems worldwide, including but not limited to Asia Pacific, Europe, and the Americas. See Cisco IOS release notes for more information.

8 Related Documentation

For more information, refer to the following at [Cisco.com](http://www.cisco.com):

- [Cisco uBR7200Series Universal Broadband Hardware Installation Guide](#)
- [Cisco uBR7200 Series Cable Interface Line Card Installation Guide](#)
- [Cisco uBR7200 Series Universal Broadband Software Configuration Guide](#)
- [Cisco CMTS Error Messages](#)
- [Cisco CMTS Feature Guide](#)

For information about the 1–year warranty, see the following URL:
http://www.cisco.com/en/US/products/prod_warra nties_listing.html